



**Technical Service  
BULLETIN**

June 14, 2006

Title:

**BACK DOOR POWER  
WINDOW INOPERATIVE**

Models:

'01 – '06 Sequoia

**ELECTRICAL  
EL007-06**

**Introduction** Some 2001 – 2006 model year Sequoia vehicles may experience a condition where the back door power window of the vehicle is inoperative/stuck in the closed position. The following procedure has been developed to address this condition.

- Applicable Vehicles**
- **2001 – 2006** model year **Sequoia** vehicles produced **BEFORE** the Production Change Effective VINs shown below.

**Production  
Change  
Information**

MODEL	DRIVETRAIN	PRODUCTION CHANGE EFFECTIVE VIN
Sequoia	2WD	5TDZT3#A#6S271567
	4WD	5TDBT4#A#6S264960

**Parts  
Information**

MODEL YEAR	PREVIOUS PART NUMBER	CURRENT PART NUMBER	PART NAME	QTY
2001 – 2004	85710-0C030	Same	Motor Assembly	1
	85710-0C070	Same		1
2005 – 2006	89222-0C020	89222-0C021	ECU	1
	90269-05035	Same	Rivet	2

**Warranty  
Information**

OP CODE	DESCRIPTION	MODEL YEAR	TIME	OPF	T1	T2
EL5075	Remove Stop and R & R Back Door Power Window Motor	2001 – 2006	0.9	85710-0C030	72	83
Combo A	R & R Back Door ECU	2005 – 2006 Only	0.3			

**Applicable Warranty\*:**

**This repair is covered under the Toyota Comprehensive Warranty. This warranty is in effect for 36 months or 36,000 miles, whichever occurs first, from the vehicle's in-service date.**

\* Warranty application is limited to correction of a problem based upon a customer's specific complaint.



Required SSTs

ITEM NO.	SPECIAL SERVICE TOOLS (SSTs)	PART NUMBER	QTY	DRW**
1	<b>Plastic Pry Tool Set*</b> NOTE: • All components from this kit/set are required	00002-06000-01	1	21

\* Essential SSTs.

\*\* Refers to drawer number in SST Storage System.

**NOTE:**  
 Additional SSTs may be ordered by calling SPX/OTC at 1-800-933-8335.

Repair Procedure

1. Disconnect the negative (-) terminal of the vehicle battery.

**NOTE:**  
 Any time the negative (-) battery terminal has been disconnected, systems requiring initialization will need to be re-initialized after the negative (-) battery terminal has been reconnected.

2. Open the back door and leave open.
3. Using the plastic pry tool, remove the back door garnish center.

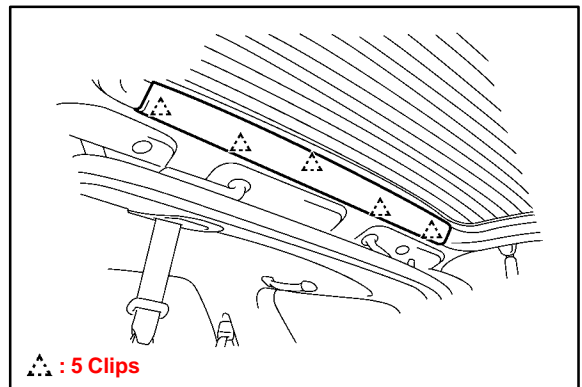

4. Using the plastic pry tool, remove the left and right back door side garnish panels.

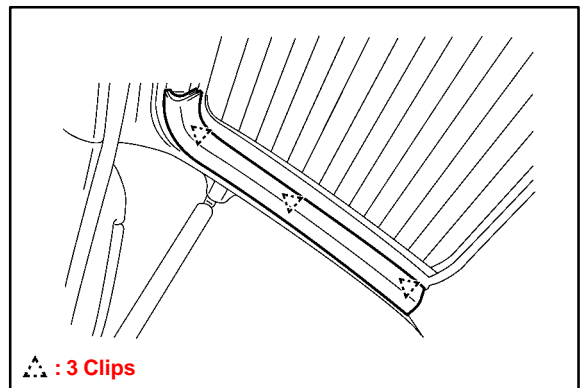

**Repair Procedure**  
(Continued)

5. Remove the strap cover, bolt, and pull strap.

**NOTE:**

To remove the strap cover, push it toward the back door window as shown in the illustration.

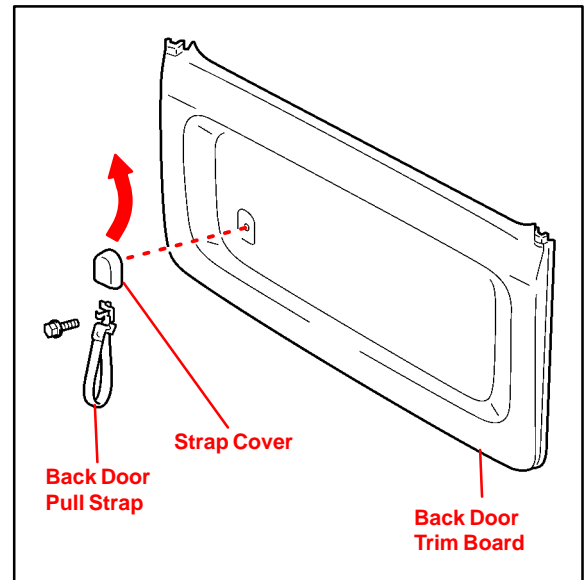

6. Remove the back door trim board.
- A. Insert the plastic pry tool between the back door trim board to release the clips retaining the back door trim.

**NOTE:**

Be careful NOT to damage the back door and back door trim board.

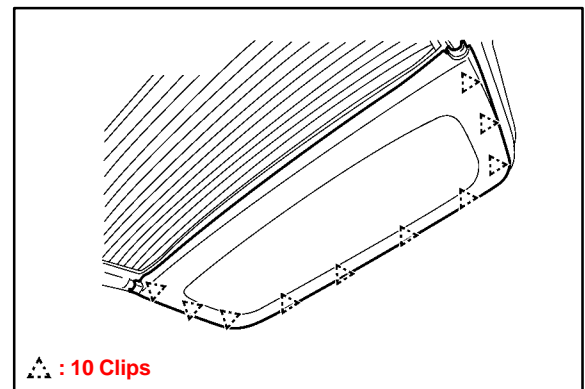

- B. Release each clip as shown in the illustration.
7. Disconnect both connectors to the back door ECU and both clips holding the wire harness to the large service cover.
8. Remove both of the back door service hole covers.
- For **2001 – 2004** model year Sequoia vehicles, go to step 11.
  - For **2005 – 2006** model year Sequoia vehicles, continue to step 9.
9. **For 2005 – 2006 model year Sequoia vehicles ONLY:**  
Remove the multiplex network door ECU.  
Using a drill of less than 3.2 mm (0.126 in.), drill out the two (2) rivet heads.

**HINT:**

Gently and vertically put the drill to the rivets and cut the rivet flanges.

**CAUTION:**

Take care as the cut rivets may be HOT.

10. **For 2005 – 2006 model year Sequoia vehicles ONLY:**  
Install the replacement multiplex network door ECU and rivets.

**Repair Procedure**  
(Continued)

11. Remove the back door power window regulator.
- A. Remove the four (4) nuts to the power window regulator and slide the regulator and glass down until the four (4) bolts appear in the service holes.

**Torque: 8.0 N•m (82 kgf•cm, 71 in.•lbf)**

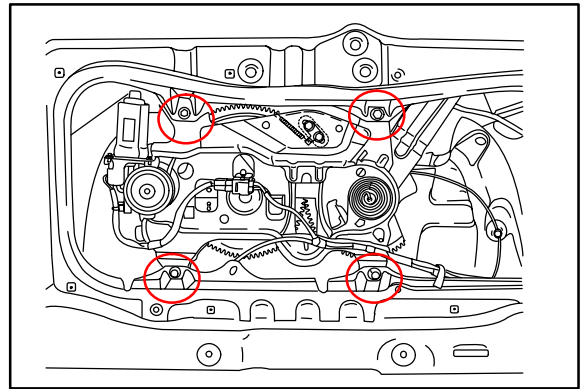

- B. Remove the four (4) bolts attaching the regulator to the back door glass.

**Torque: 8.0 N•m (82 kgf•cm, 71 in.•lbf)**

**NOTE:**

Be careful NOT to drop the back door glass or close the back door without supporting the glass.

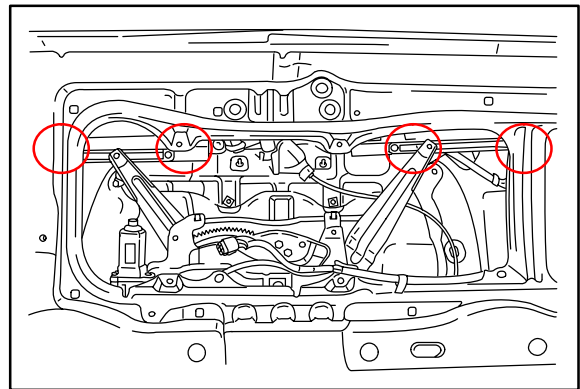

12. Disconnect the back door power window regulator assembly.
- A. Disconnect the power window motor connector.
- B. Disconnect both wire harness clips from the regulator.

**HINT:**

Remove the power window regulator through the service hole.

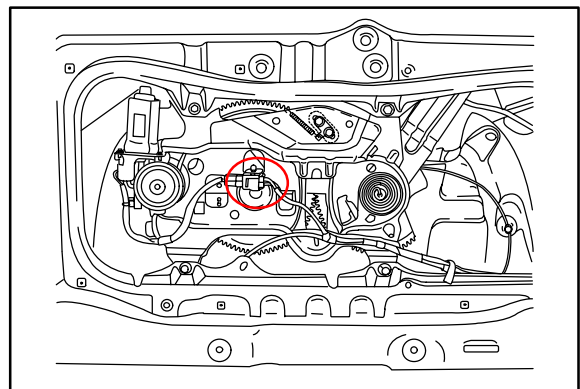

13. Remove and replace the back door power window motor on the back door power window regulator assembly.
- A. Remove the three (3) screws and power window regulator motor from the power window regulator.

**NOTE:**

At the time of reassembly, do NOT apply grease to the spring of the power window regulator.

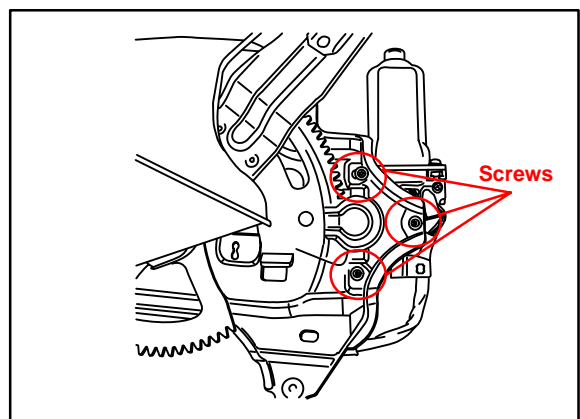

**Repair  
Procedure**  
(Continued)

14. Locate, remove, and discard the metal stopper.

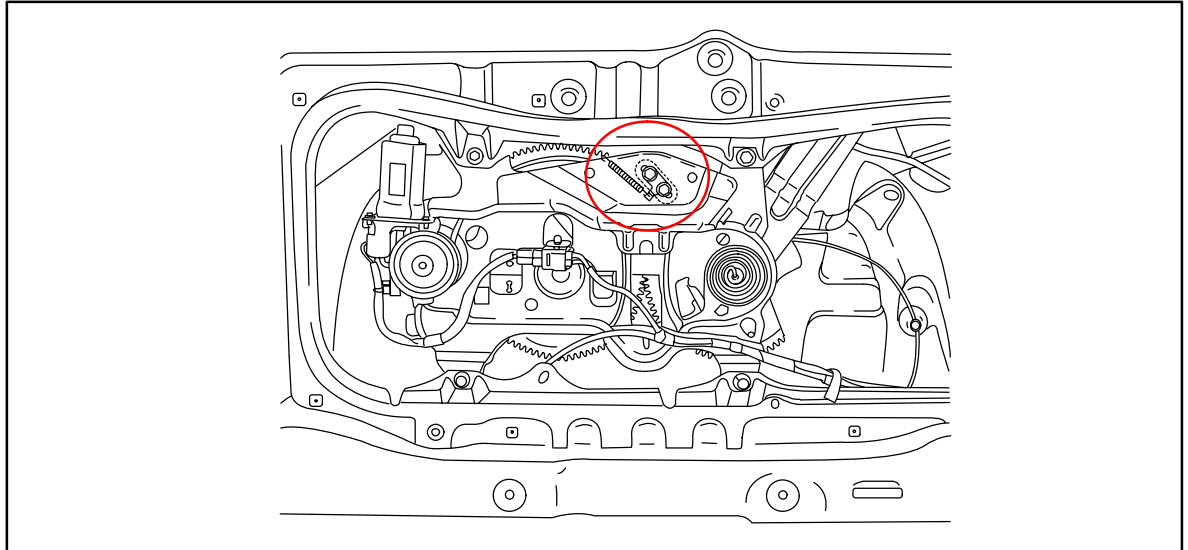

- A. Remove and discard the spring between the stopper and the regulator frame.
- B. Remove the two (2) bolts that hold the stopper in place on the regulator.  
There is a backing plate on the backside that the two (2) bolts fasten to. The backing plate will be loose when the two (2) bolts are removed. Be sure to remove the backing plate and discard it from the vehicle.

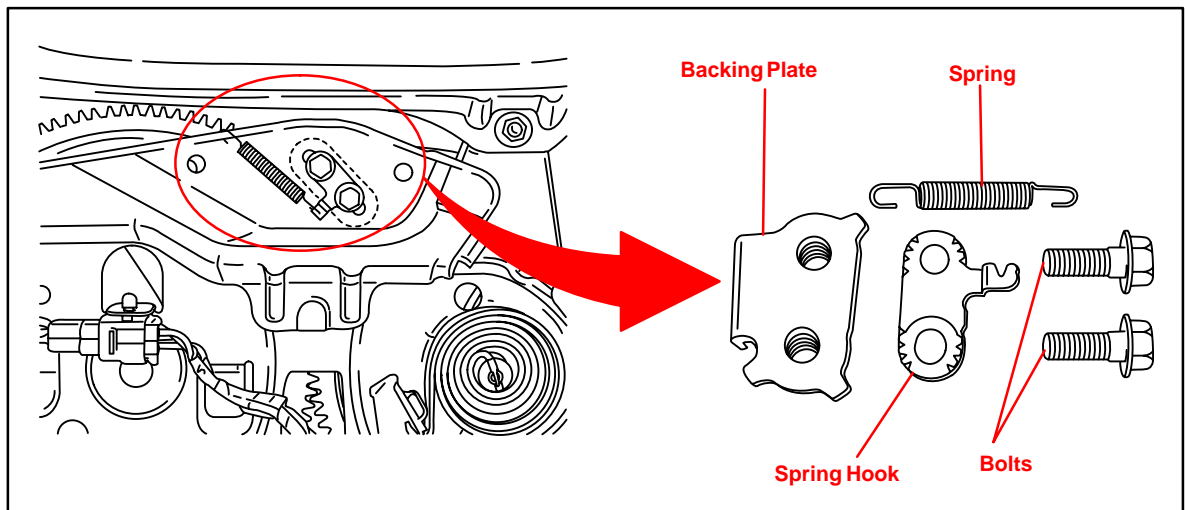

15. Install the back door power window motor.

**NOTE:**

The NEW motor will NOT be pre-threaded so it will take more effort to secure the three (3) fasteners into the motor. Be careful NOT to strip the threads out of the motor by over-torquing the fasteners.

Torque: 5.5 N•m (56 kgf•cm, 49 in.•lbf)

**Repair  
Procedure**  
(Continued)

16. Install the back door power window regulator assembly and back door components in reverse order of removal.
17. Reconnect the negative (-) battery terminal.
18. Perform back door power window initialization and confirm window operation.

- A. Turn the ignition switch to the “ON” position.
- B. Push the back door power window switch to the “DOWN” side to open the window.
- C. Push and hold the back door power window switch to the “UP” side until the window closes. Continue holding it for approximately one second.
- D. Check for proper operation of the “one-touch open/close” functions by pushing the switch briefly to the “DOWN” and “UP” sides.

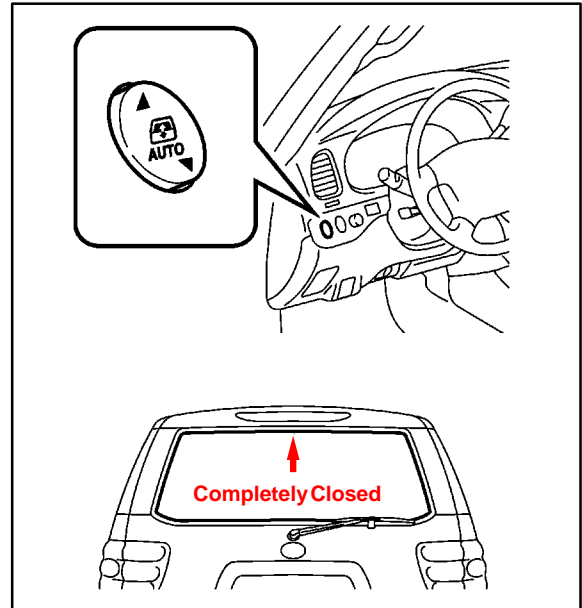
**NOTE:**

**Jam protection function becomes effective through the above initialization procedure.**

19. Initialize and confirm operation of all other power systems requiring initialization. Refer to TSB No. PD014-06, “Power System Initialization During PDS”.